

# Copper Ball Check Valve

Parker ball check valves contain a stainless steel ball that is in a one piece brass seat and retainer assembled in a copper tube. The materials of construction are corrosion proof and allow the check valve to be used at a wide range of operating temperatures and conditions. Spring loaded versions are available upon request.

## Key Features & Benefits

- Straight flow through design yields high flow capacities for small diameter valve bodies.
- Metal to metal seating - stainless steel to brass
- Corrosion resistant construction (Stainless steel, brass, copper).
- Leak rate - dry : 750 cc/min
- UL recognised for 35 bar design pressure (No. SA3604)
- Small body diameter
- One piece body construction eliminates leaks
- All metal design allows for higher installation and operating temperatures.

*Note: Valves should be installed at an angle to ensure proper seating in off cycle.*

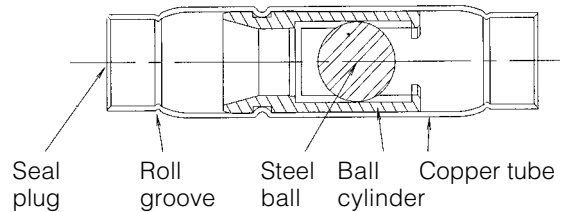
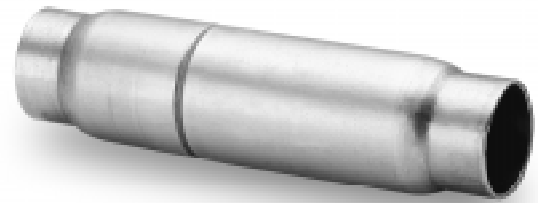

Model No.	UL Model	Female Sweat Connections	Overall Length	System Cutout Length	Body Diameter	Kw* @ 0.07 bar pressure drop						
						12	22	134a	404A	407C	410A	502
CV4-6FS-6FS	3/8F	3/8	95	76	13	9,2	12,3	11,2	8,0	11,9	12,1	8,0
CV5-8FS-8FS	1/2F	1/2	95	73	16	16,9	22,5	20,4	14,7	21,7	22,1	14,7
CV7-10FS-10FS	5/8F	5/8	114	89	22	31,7	42,2	38,4	27,4	40,8	41,5	27,4
CV9-14FS-14FS	7/8F	7/8	114	89	29	65,2	87,0	79,1	56,5	84,0	85,6	56,5
CV11-18FS-18FS	1 1/8F	1 1/8	127	102	35	171,3	228,5	207,8	148,0	220,9	224,8	148,0

\* Rated at 30°C liquids/-15°C evaporator (85°F/5°F)

# Soft Seat Copper Check Valve

Instead of the metal-metal seating found in many check valves, this Parker valve features a neoprene O-ring that seats to a brass seat. This "soft seat" design guarantees virtually no leakage of refrigerant.

## Key Features & Benefits

- Neoprene o-ring seal is compatible with currently used HCFCs, HFCs and their associated lubricants.
- Ideal for refrigeration and air conditioning applications where extremely low leakage is a requirement.
- After 300,000 cycles, at a 7 bar differential pressure, maximum leak rate is 10cc/min. Traditional check valves have leak rates of up to 750cc/min.
- Features a brass piston and a steel piston stop.
- Valve sizes available are 1/4", 5/16" and 3/8"
- Operating temperature range of -40°C to 150°C

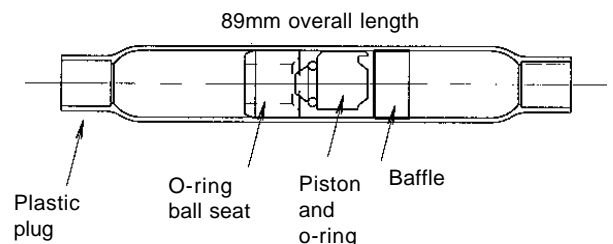
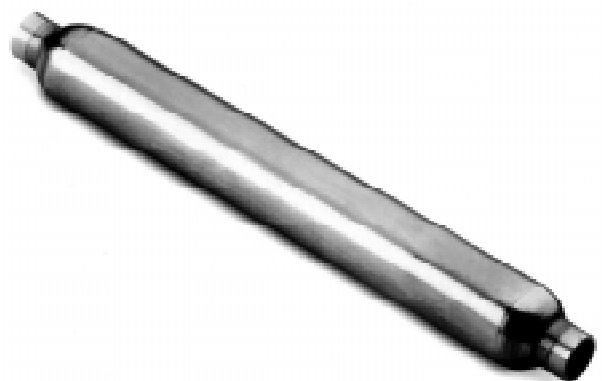

# Brass Check Valves

## 1/4" Brass Check Valve

- Poppet style valve incorporates o-ring sealing surface.
- Brass body and piston resist corrosion.
- Stainless steel spring resists corrosion.
- Braze connections.

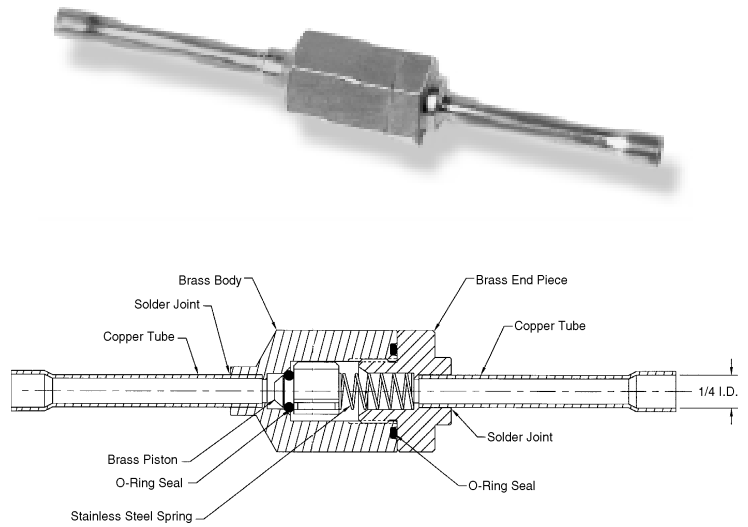
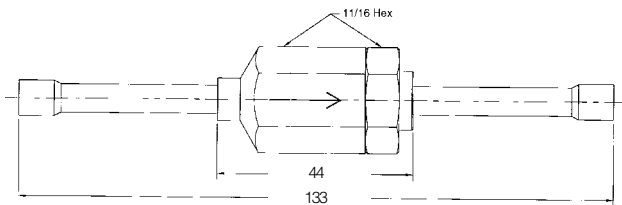

## 3/8" Brass Check Valve

- Poppet style valve incorporates o-ring sealing surface.
- Brass body and piston resist corrosion.
- Stainless steel spring resists corrosion.
- Braze connections.

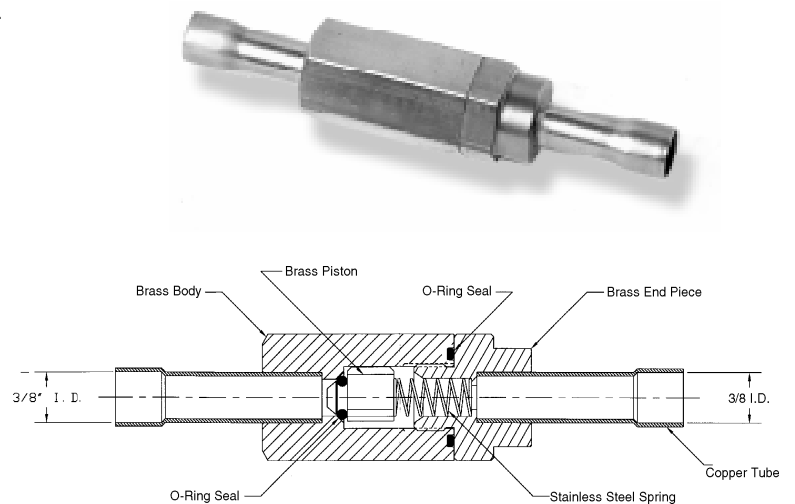
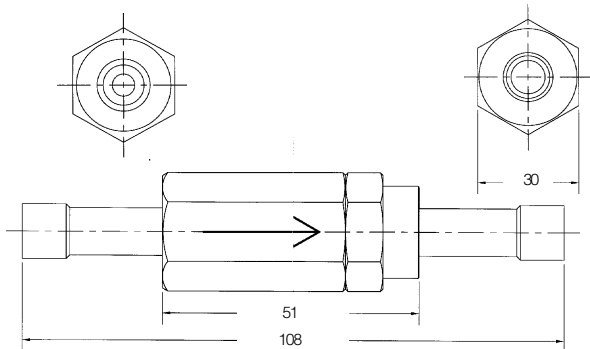

## 1/8" NPT Brass Check Valve

- Poppet style valve incorporates o-ring sealing surface.
- Brass body and piston resist corrosion.
- Stainless steel spring resists corrosion.
- Female NPT threaded connections.

